

Size 14 (35mm) Series

Motor Characteristics

Motor	Voltage (V)	Current (A)	Resistance (Ω)	Inductance (mH)	Lead Wire No.	Motor Length (mm)
14E2110	3.5	1	3.5	3.6	4	33.6
14E2115	2.7	1.5	1.8	1.9	4	33.6
14E2210	6	1	6	7.2	4	45.6
14E2215	4	1.5	2.7	3.2	4	45.6

Dimensional Drawings

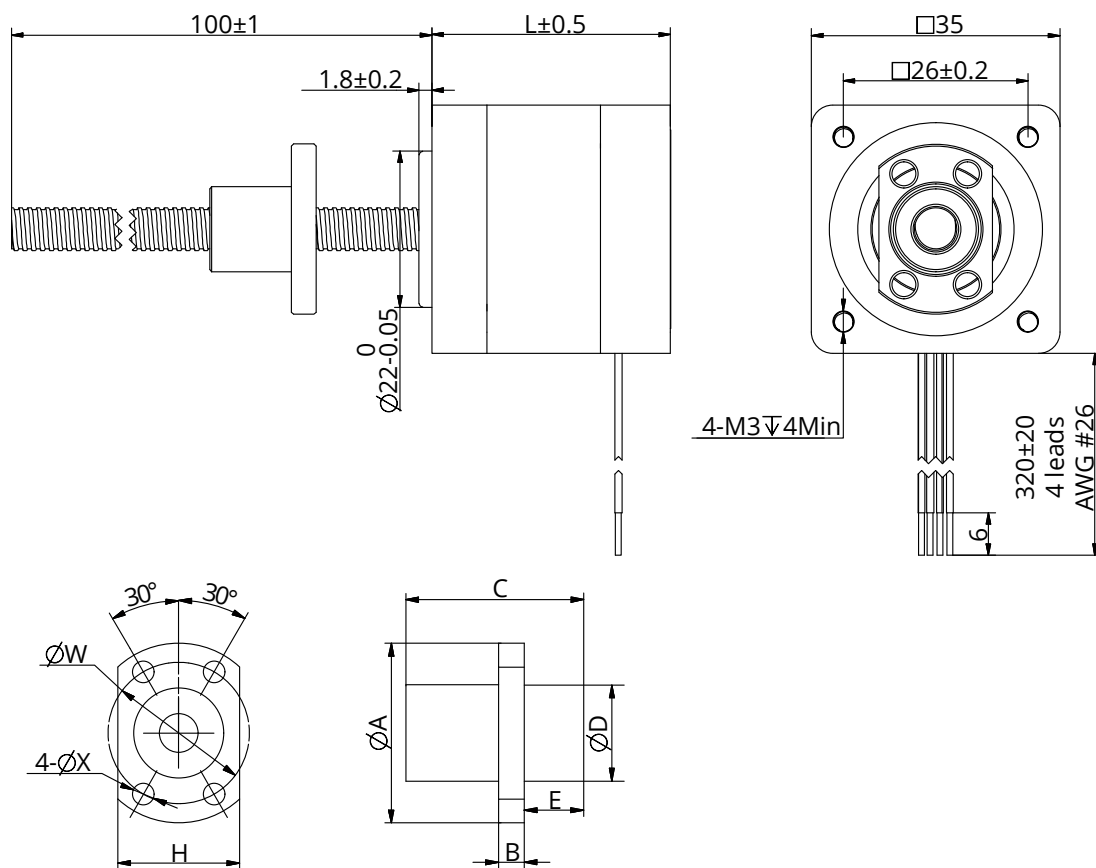

Note : All drawings are 1st Angle Projection - ISO Compliant (3D models available)

Size 14 (35mm) Series

Speed Thrust Curves

Size 14 Single Stack Speed Thrust Curves

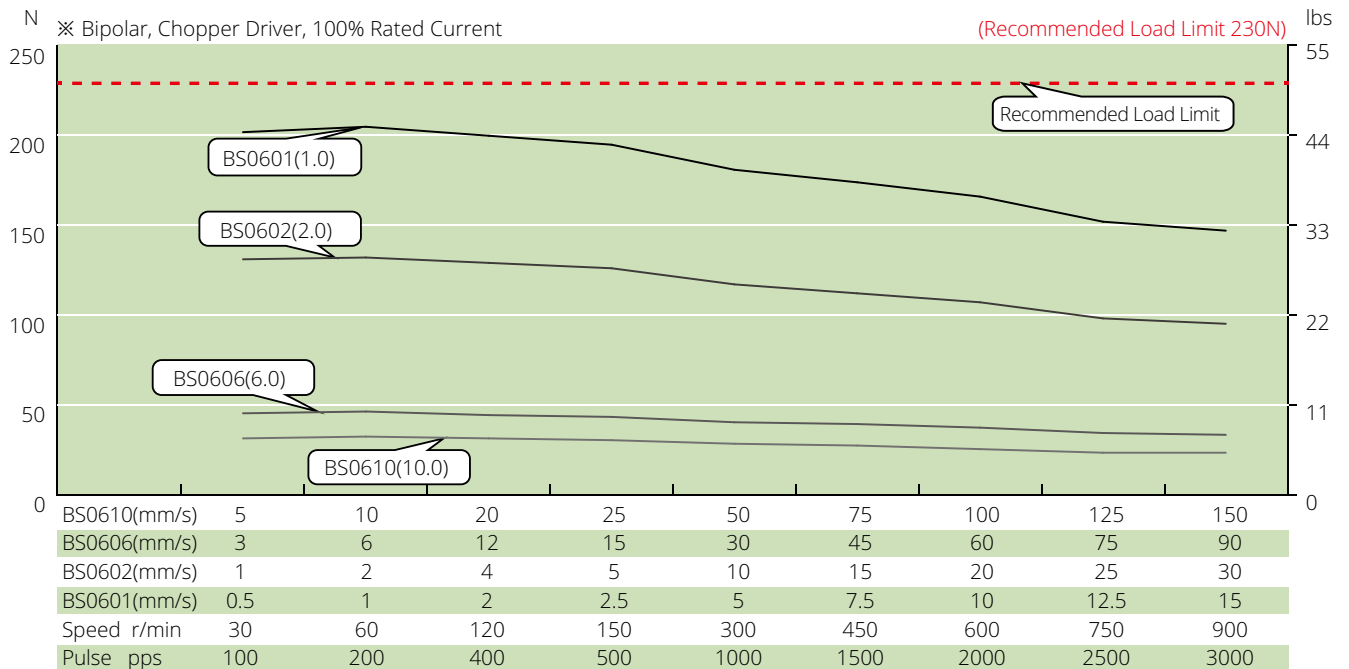

Size 14 Double Stack Speed Thrust Curves

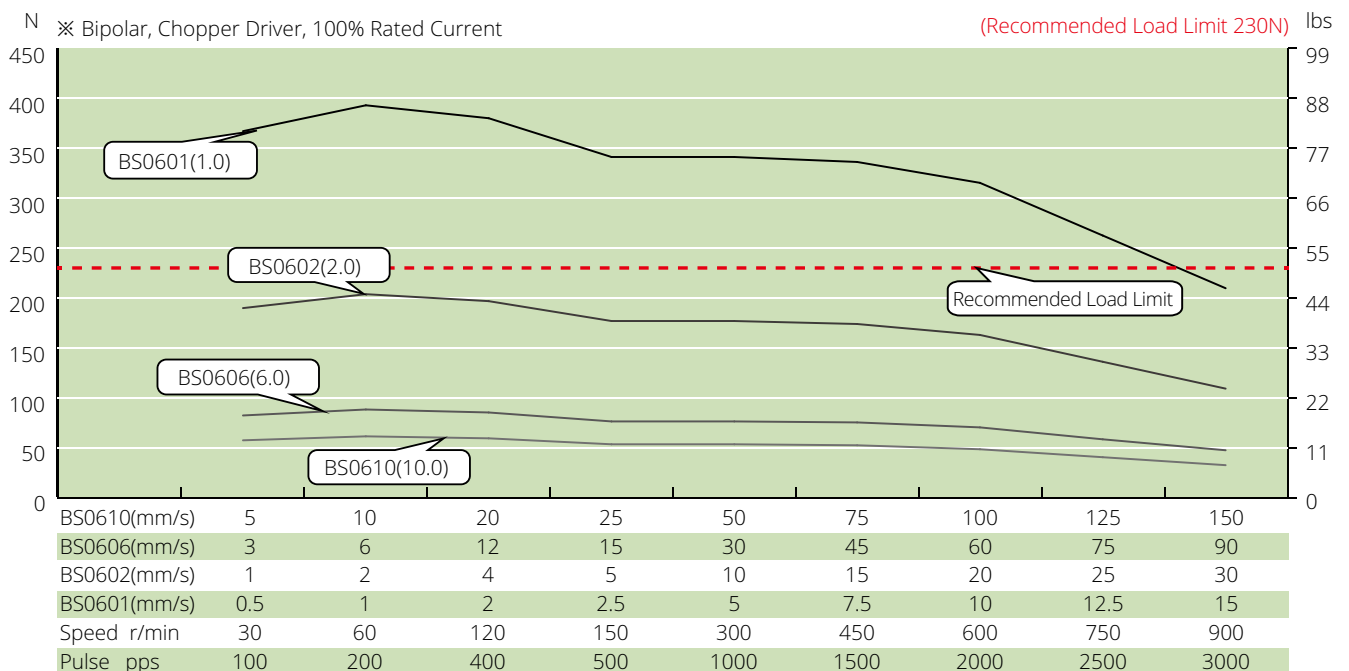

TEST CONDITION

Testing Voltage: 24Vdc, Driver Model: DS-OLS2-FPD bipolar, chopper driver at rated current (rms).
Motor's thrust will be changed with different voltage and driver. 50% thrust margin is recommended.